

SAIBO
Innovation in Motion

ROMANI
COMPONENTS

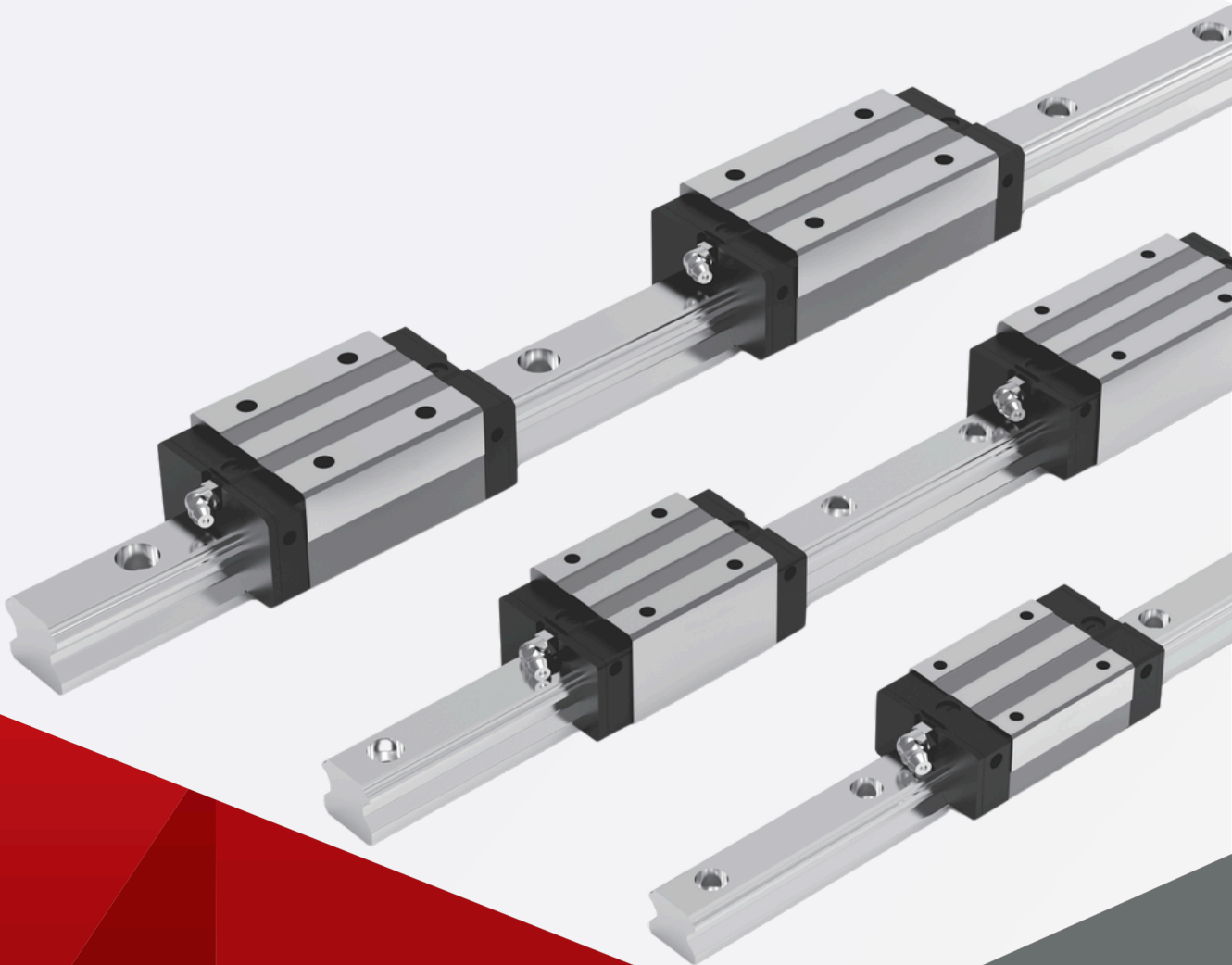

LINEAR GUIDE

SAIBO is one of world recognized manufacturers of precision power transmission components. SAIBO group has two divisions, linear motion division and bearing division. Linear Product Division mainly produces curved rail and conveyor, telescopic rail and fork, linear guide, linear module, belt conveyor etc. Bearing Division mainly produces Thin-section bearing, High-speed angular contact ball bearing, linear bearing etc.

SAIBO products are widely used in 3C, factory automation, precision machine, green energy, rail transportation, medical and pharmacy etc. industries. SAIBO end users are located in more than 50 countries and regions around the world.

SAIBO has over 33,000 square meters producing facilities totally and 350 employees. SAIBO continues to develop innovative automation components and modulars to meet customers sustainable solutions.

SAIBO means aim for greatness, focus on details. We seek to work with you and promise the following:

- The right product from your application
- A quality product you can trust
- Engineering assistance that is proven and world renown

RMB Steel Ball Type Linear Guide

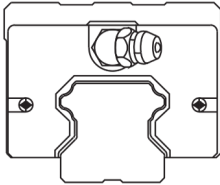

Steel balls circulate in four-rows raceways. Heavy load capacity, high accuracy.

P4 –P8

RMBE Steel Ball Type Linear Guide

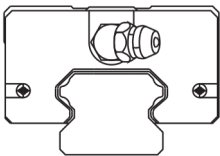

RMBE linear guide has same structure with RMB but the assembly height is lower. Suitable for medium and heavy load capacity, high accuracy and compact space applications.

P9 –12

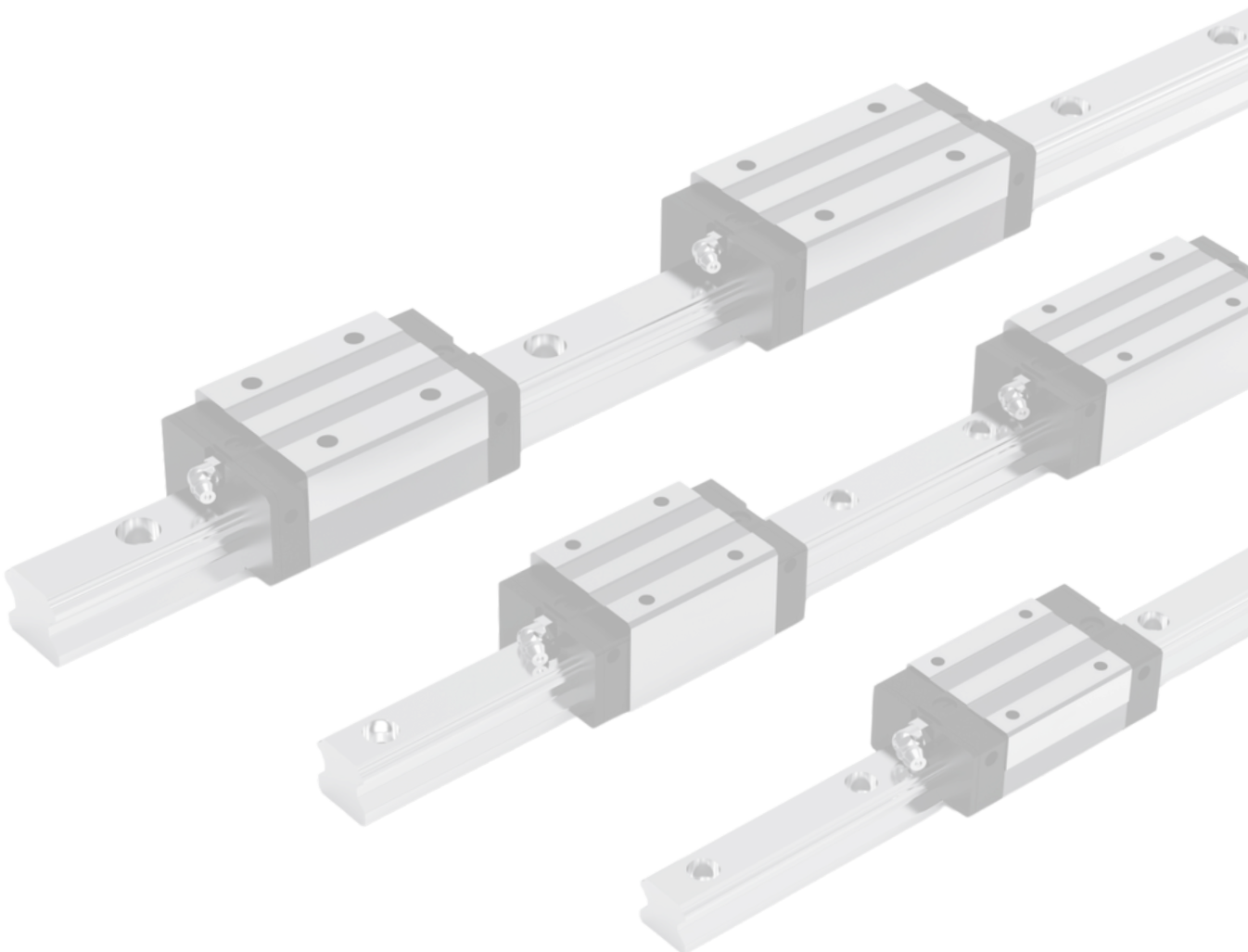

RMB Steel Ball Type Linear Guide

Structure

RMB linear guide is composed of a rail and carriage(s). Steel balls circulate inside the carriage through the reverse caps at both ends of the carriage. By the designing of four-row raceways, 45degrees contact angles, it has not only equal heavy load capacity in radial and axial directions with high rigidity, but also self-aligning capability to realize high accuracy and smooth operation.

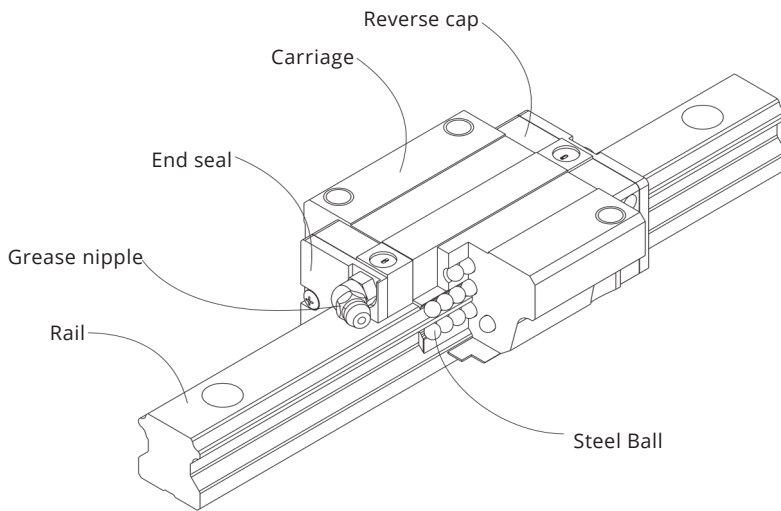

Carriage Types

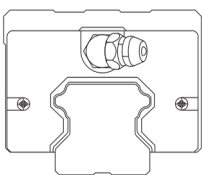

RMB - SL/SLL

RMB Square (Higher) type carriage. This assembly height is higher than another two types. Only top mounting available.

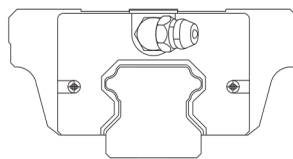

RMB - FL/FLL

RMB Flange type carriage. This type carriage is suitable for heavy moment load application because of lower assembly height and wider mounting surface. Top mounting and bottom mounting are available.

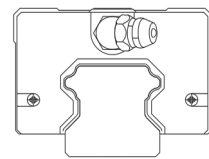

RMB - HL/HLL

RMB Square (Lower) type carriage. This assembly height is same as flange type. Only top mounting available.

Accuracy

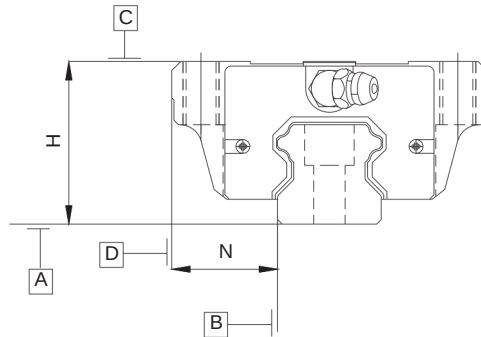

Accuracy Classes	HG-15,20			HG-25,30,35		
	Normal (C)	High (H)	Precision (P)	Normal (C)	High (H)	Precision (P)
Dimensional tolerance of height H	±0.1	±0.03	±0.015	±0.1	±0.04	±0.02
Dimensional tolerance of width N	±0.1	±0.03	±0.015	±0.1	±0.04	±0.02
Variation of height H	0.02	0.01	0.006	0.02	0.015	0.007
Variation of height N	0.02	0.01	0.006	0.03	0.015	0.007

Accuracy Classes	HG-45,55			HG-65		
	Normal (C)	High (H)	Precision (P)	Normal (C)	High (H)	Precision (P)
Dimensional tolerance of height H	±0.1	±0.05	±0.025	±0.1	±0.07	±0.035
Dimensional tolerance of width N	±0.1	±0.05	±0.025	±0.1	±0.07	±0.035
Variation of height H	0.03	0.015	0.007	0.03	0.02	0.01
Variation of height N	0.03	0.02	0.01	0.03	0.025	0.015

Running Parallelism

Rail Length (mm)	Running parallelism of block surface C to surface A			Running parallelism of block surface D to surface B		
	Accuracy (µm)					
	C	H	P	SP	UP	
-100	12	7	3	2	2	
100-200	14	9	4	2	2	
200-300	15	10	5	3	2	
300-500	17	12	6	3	2	
500-700	20	13	7	4	2	
700-900	22	15	8	5	3	
900-1100	24	16	9	6	3	
1100-1500	26	18	11	7	4	
1500-1900	28	20	13	8	4	
1900-2500	31	22	15	10	5	
2500-3100	33	25	18	11	6	
3100-3600	36	27	20	14	7	
3600-4000	37	28	21	15	7	

RMB Linear Guide
RMB - SL/RMB-SLL Block

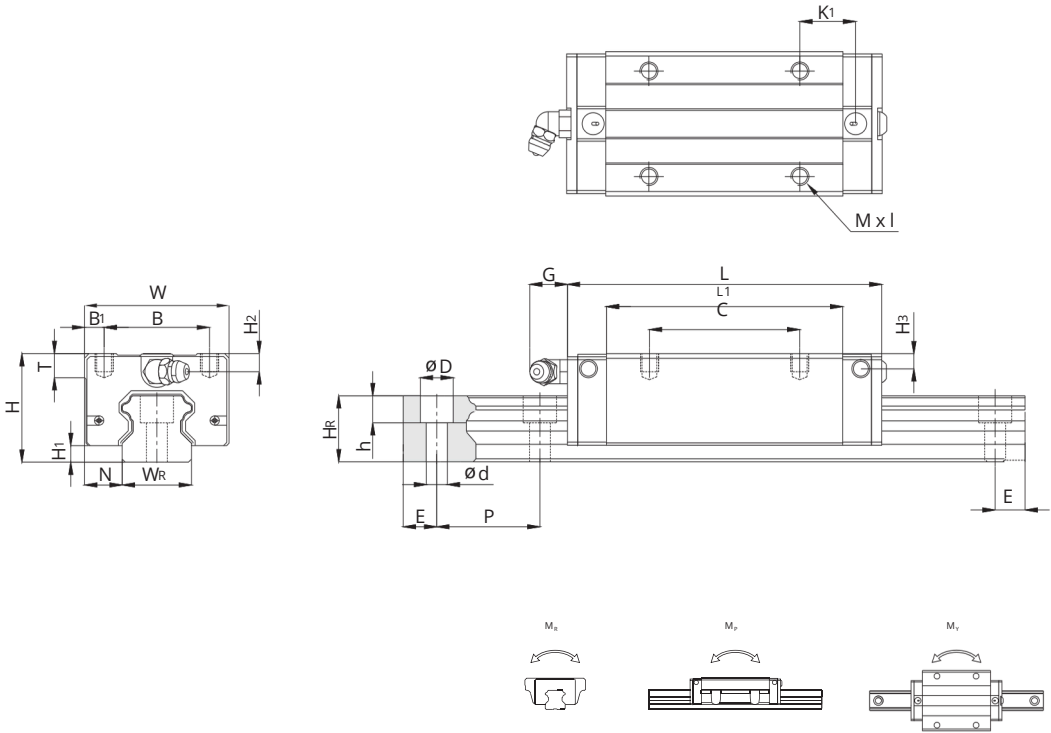

Model No.	Dimensions of Assembly (mm)			Dimensions of Block (mm)											Dimensions of Rail (mm)					Mounting Bolt for Rail (mm)	Basic Dynamic Load Rating C(kN)	Basic Static Load Rating C0(kN)	Static Rated Moment			Weight					
	H	H1	N	W	B	B1	C	L1	L	K1	G	Mxl	T	H2	H3	WR	HR	D	h				d	p	E	M	Mp	Mv	Block kg	Rail kg/m	
																										kN-m	kN-m	kN-m			
RMB 15 SL	28	4.3	9.5	34	26	4	26	39.5	61.4	10	5.3	M4x5	6	7.95	7.7	15	15	7.5	5.3	4.5	60	20	M4x16	11.38	16.97	0.12	0.10	0.10	0.18	1.45	
RMB 20 SL	30	4.6	12	44	32	6	36	50.5	76.7	12.25	12	M5x6	8	6	6	20	17.5	9.5	8.5	6	60	20	M5x16	17.75	27.76	0.27	0.20	0.20	0.30	2.21	
RMB 20 SLL							50	65.2	91.4	12.6														21.18	35.9	0.35	0.35	0.35	0.39		
RMB 25 SL	40	5.5	12.5	48	35	6.5	35	58	84	15.7	12	M6x8	8	10	9	23	22	11	9	7	60	20	M6x20	26.48	36.49	0.42	0.33	0.33	0.51	3.21	
RMB 25 SLL							50	78.6	104.6	18.5														32.75	49.44	0.56	0.57	0.57	0.69		
RMB 30 SL	45	6	16	60	40	10	40	70	98.4	20.25	12	M8x10	8.5	9.5	13.8	28	26	14	12	9	80	20	M8x25	38.74	52.19	0.66	0.53	0.53	0.88	4.47	
RMB 30 SLL							60	93	121.4	21.75														47.27	69.16	0.88	0.92	0.92	1.16		
RMB 35 SL	55	7.5	18	70	50	10	50	80	112.4	20.6	12	M8x12	10.2	16	19.6	34	29	14	12	9	80	20	M8x25	49.52	69.16	1.16	0.81	0.81	1.45	6.30	
RMB35SLL							72	105.8	138.2	22.5														60.21	91.63	1.54	1.40	1.40	1.92		
RMB 45 SL	70	9.5	20.5	86	60	13	60	97	137.4	23	12.9	M10x17	16	18.5	30.5	45	38	20	17	14	105	22.5	M12x35	77.57	102.71	1.98	1.55	1.55	2.73	10.41	
RMB 45 SLL							80	128.8	169.2	28.9														94.54	136.46	2.63	2.68	2.68	3.61		
RMB 55 SL	80	13	23.5	100	75	12.5	75	117.7	166.7	27.35	12.9	M12x18	17.5	22	29	53	44	23	20	16	120	30	M14x45	114.44	148.33	3.69	2.64	2.64	4.17	15.08	
RMB 55 SLL							95	155.8	204.8	36.4														139.35	196.2	4.88	4.57	4.57	5.49		
RMB 65 SL	90	15	31.5	126	76	25	70	144.2	200.2	43.1	12.9	M16x20	25	15	15	63	53	26	22	18	150	35	M16x50	163.63	215.33	6.65	4.27	4.27	7.00	21.18	
RMB 65 SLL							120	203.6	259.6	47.8														208.36	303.13	9.38	7.38	7.38	9.82		

RMB Linear Guide

RMB-HL/RMB-HLL Block

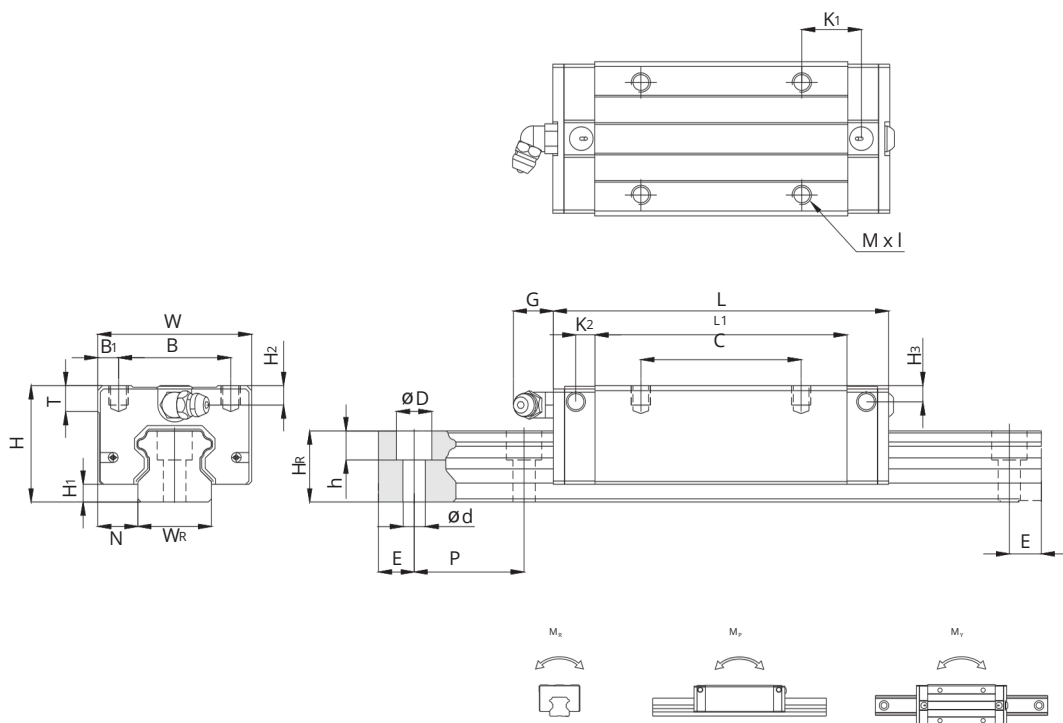

Model No.	Dimensions of Assembly (mm)			Dimensions of Block (mm)										Dimensions of Rail (mm)							Mounting Bolt for Rail (mm)	Basic Dynamic Load Rating C (kN)	Basic Static Rating C ₀ (kN)	Static Rated Moment			Block Weight (kg)	Rail Weight (kg/m)				
	H	H ₁	N	W	B	B ₁	C	L ₁	L	K ₁	K ₂	G	M x l	T	H ₂	H ₃	W _R	H _R	D	d				P	E	M _R			M _P	M _V		
RMB 15HL	244.3	9.5	34	26	4	26	39.5	61.4	10	4.85	5.3	M4x4	6	3.95	3.7	15	15	7.5	5.3	4.5	60	20	M4x16	11.38	16.97	0.12	0.10	0.10	0.14	1.45		
RMB 25HL	36	5.5	12.5	48	35	6.5	35	58	84	15.7	6	12	M6x6	8	6	5	23	22	11	9	7	60	20	M6x20	26.48	36.49	0.42	0.33	0.33	0.42	3.21	
RMB 25HLL							50	78.6	104.6	18.5															32.75	49.44	0.56	0.57	0.57	0.57		
RMB 30HL	42	6	16	60	40	10	40	70	98.4	20.25	6	12	M8x10	8.5	6.5	10.8	28	26	14	12	9	80	20	M8x25	38.74	52.19	0.66	0.53	0.53	0.78	4.47	
RMB 30HLL							60	93	121.4	21.75															47.27	59.16	0.88	0.92	0.92	1.03		
RMB 35HL	48	7.5	18	70	50	10	50	80	112.4	20.6	7	12	M8x12	10.2	9	12.6	34	29	14	12	9	80	20	M8x25	49.52	69.16	1.16	0.81	0.81	1.14	6.30	
RMB 35HLL							72	105.8	138.2	22.5															60.21	91.63	1.54	1.40	1.40	1.52		
RMB 45HL	60	9.5	20.5	86	60	13	60	97	137.4	23	10	12.9	M10x17	16	8.5	20.5	45	38	20	17	14	105	22.5	M12x35	77.57	102.71	1.98	1.55	1.55	2.08	10.41	
RMB 45HLL							80	128.8	169.2	28.9															94.54	136.46	2.63	2.68	2.68	2.75		
RMB 55HL	70	13	23.5	100	75	12.5	75	117.7	166.7	27.35	11	12.9	M12x18	17	15	12	19	53	44	23	20	16	120	30	M14x45	114.44	148.33	3.69	2.64	2.64	3.25	15.08
RMB55HLL							95	155.8	204.8	36.4																139.35	196.2	4.88	4.57	4.57	4.27	

RMBE Steel Ball Type Linear Guide

Structure

RMBE linear guide structure is same as RMB type. Four-row raceways, 45degrees contact angles designing. It has not only equal heavy load capacity in radial and axial directions with high rigidity, but also self-aligning capability to realize high accuracy and smooth operation. RMBE assembly height is lower than RMB type. Heavy load and medium load carriages are designed to meet different applications.

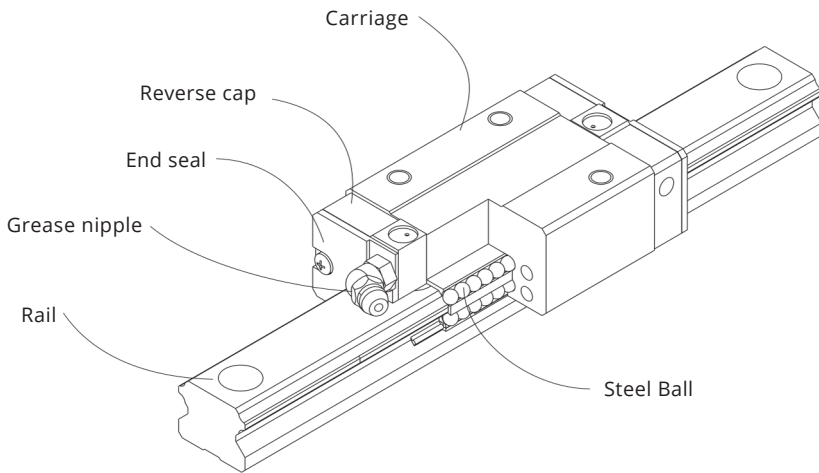

Carriage Types

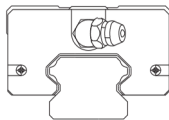

RMB-ESV/ECL

RMB-ESV/ECL Square type carriage. Assembly height is lower than RMB - SL/SLL, fit for compact space applications.

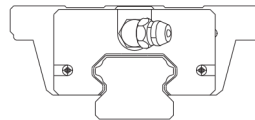

RMB-EFV/EFL

RMB-EFV/EFL Flange type carriage. Assembly height is same as RMB-ESV/ECL. This type carriage is suitable for heavy moment load application because of lower assembly height and wider mounting surface. Top mounting and bottom mounting are available.

Accuracy

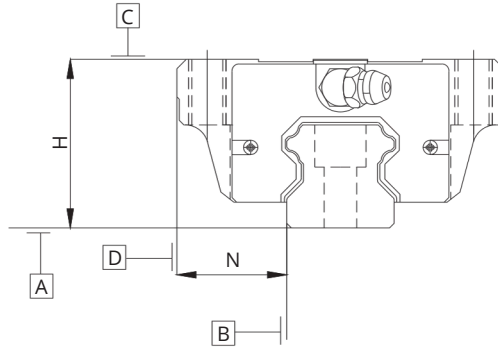

Accuracy Classes	EG-15,20			EG-25,30		
	Normal (C)	High (H)	Precision (P)	Normal (C)	High (H)	Precision (P)
Dimensional tolerance of height H	± 0.1	± 0.03	± 0.015	± 0.1	± 0.04	± 0.02
Dimensional tolerance of width N	± 0.1	± 0.03	± 0.015	± 0.1	± 0.04	± 0.02
Variation of height H	0.02	0.01	0.006	0.02	0.015	0.007
Variation of height N	0.02	0.01	0.006	0.03	0.015	0.007

Running Parallelism

Rail Length (mm)	Running parallelism of block surface C to surface A			Running parallelism of block surface D to surface B		
	Accuracy (µm)					
	C	H	P	SP	UP	
–100	12	7	3	2	2	
100–200	14	9	4	2	2	
200–300	15	10	5	3	2	
300–500	17	12	6	3	2	
500–700	20	13	7	4	2	
700–900	22	15	8	5	3	
900–1100	24	16	9	6	3	
1100–1500	26	18	11	7	4	
1500–1900	28	20	13	8	4	
1900–2500	31	22	15	10	5	
2500–3100	33	25	18	11	6	
3100–3600	36	27	20	14	7	
3600–4000	37	28	21	15	7	

RMBE Linear Guide

RMB-ESV/RMB-ECL Block

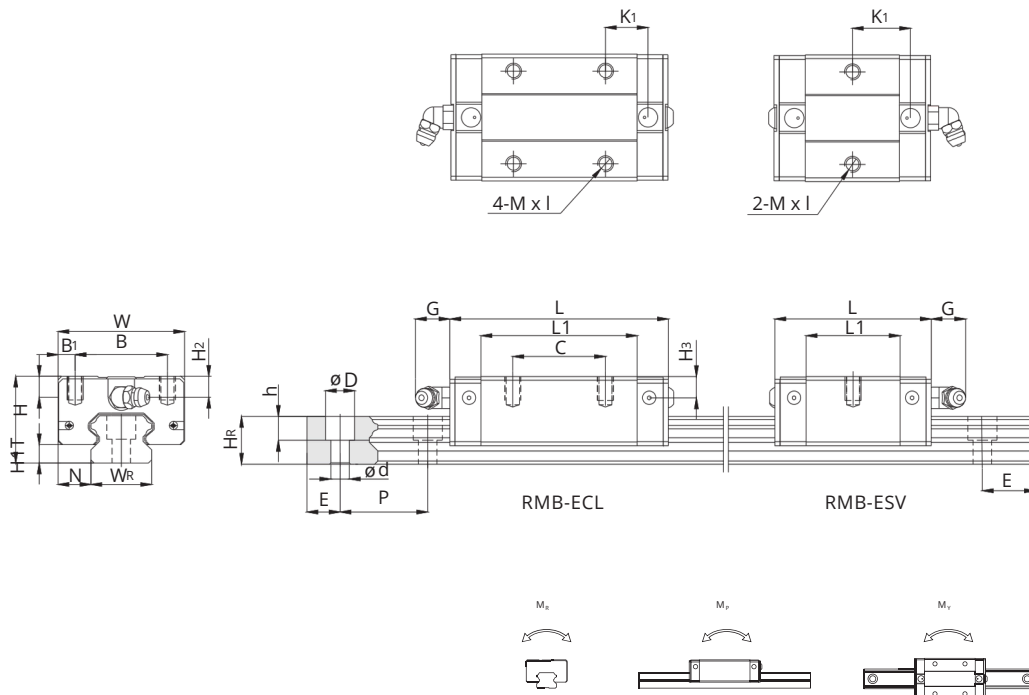

Model No.	Dimensions of Assembly (mm)			Dimensions of Block (mm)										Dimensions of Rail (mm)					Mounting Bolt for Rail (mm)	Basic Dynamic Load Rating C (kN)	Basic Static Load Rating Co (kN)	Static Rated Moment			Weight					
	H	H ₁	N	W	B	B ₁	C	L ₁	L	K	G	Mx _l	T	H ₂	H ₃	W _R	H _R	D				h	d	P	E	M _x (kN-m)	M _p (kN-m)	M _y (kN-m)	Block (kg)	Rail (kg/m)
RMB 15 ESV	24	4.5	9.5	34	26	4	-	23.1	41.1	14.8	5.7	M4x6	6	5.5	6	15	12.5	7.5	5.3	4.5	60	20	M4x16	5.35	9.40	0.08	0.04	0.04	0.09	1.25
RMB 15 ECL							26	39.8	57.8	10.15														7.83	16.19	0.13	0.10	0.10	0.15	
RMB 20 ESV	28	6	11	42	32	5	-	29	51.2	18.75	12	M5x7	7.5	6	6	20	15.5	9.5	8.5	6	60	20	M5x16	7.23	12.74	0.13	0.06	0.06	0.15	2.08
RMB 20 ECL							32	48.1	70.3	12.3																				
RMB 25 ESV	33	7	12.5	48	35	6.5	-	35.5	59.7	21.9	12	M6x9	8	8	8	23	18	11	9	7	60	20	M6x20	11.40	19.50	0.23	0.12	0.12	0.25	2.67
RMB 25 ECL							35	59	83.2	16.15																				
RMB 30 ESV	42	10	16	60	40	10	-	41.5	71.9	26.75	12	M8x12	9	8	9	28	23	14	12	9	80	20	M8x25	16.42	28.10	0.40	0.21	0.21	0.45	4.35
RMB 30 ECL							40	70	100.4	21.05																				

RMBE Linear Guide
RMB-EFV/RMB-EFL Block

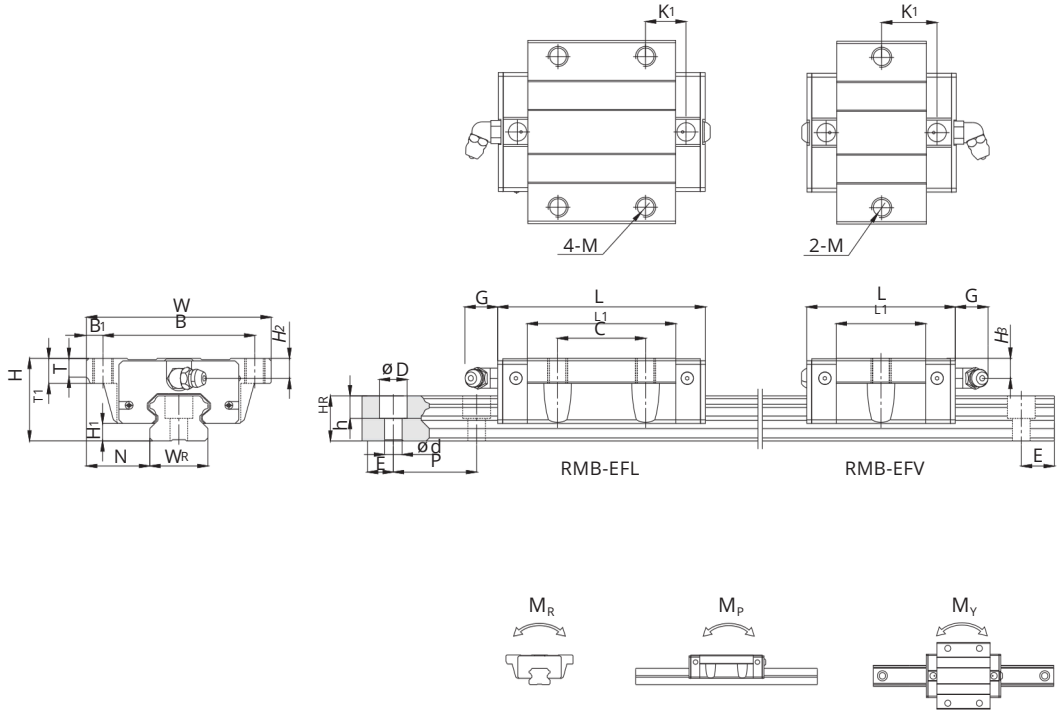

Model No.	Dimensions of Assembly (mm)		Dimensions of Block (mm)													Dimensions of Rail (mm)										Mounting Bolt for Rail (mm)	Basic Dynamic Load Rating C (kN)	Basic Static Load Rating CO (kN)	Static Rated Moment			Weight	
	H	H ₁	N	W	B	B ₁	C	L	L ₁	K	G	M	T	T ₁	H ₂	H ₃	W _R	H _R	D	h	d	P	E	M _x (kN-m)	M _y (kN-m)				M _z (kN-m)	Block (kg)	Rail (kg/m)		
RMB 15EFV	24	4.5	18.5	52	41	5.5	-	23.1	41.1	14.8	5.7	M5	5	7	5.5	6	15	12.5	7.5	5.3	4.5	60	20	M4x16	5.35	9.40	0.08	0.04	0.04	0.09	1.25		
RMB 15EFL							26	39.8	57.8	10.15															7.83	16.19	0.13	0.10	0.10	0.21			
RMB 20EFV	28	6	19.5	59	49	5	-	29	51.2	18.75	12	M6	7	9	6	6	20	15.5	9.5	8.5	6	60	20	M5x16	7.23	12.74	0.13	0.06	0.06	0.19	2.08		
RMB 20EFL							32	48.1	70.3	12.3															10.31	21.13	0.22	0.16	0.16	0.32			
RMB 25EFV	33	7	25	73	60	6.5	-	35.5	59.7	21.9	12	M8	7.5	10	8	8	23	18	11	9	7	60	20	M6x20	11.40	19.50	0.23	0.12	0.12	0.35	2.67		
RMB 25EFL							35	59	83.2	16.15															16.27	32.40	0.38	0.32	0.32	0.59			
RMB 30EFV	42	10	31	90	72	9	-	41.5	71.9	26.75	12	M10	7	10	8	9	28	23	14	12	9	80	20	M8x25	16.42	28.10	0.40	0.21	0.21	0.62	4.35		
RMB 30EFL							40	70	100.4	21.05															23.70	47.46	0.68	0.55	0.55	1.04			